



* Two Horse Model



STANDARD FEATURES

- 7' Wide (6'8" Inside) 7' Tall
- Catalyzed Polyurethane Paint / Catalyzed Two-Part Primer
- Galvanized Roof Bows / Sheeting
- Pre-Primered Tubing
- Vinyl Front & Rear Stripe Detailing
- Aluminum Diamond Plate Over Front & Fender
- Rubber Dock Bumper
- Telescoping Padded Divider
- Removable Diagonal Wall



- Full Caulking Package
- Enclosed Rear Door
- Feed Doors
- Plexiglass
- Rubber Floor Mats

AVAILABLE IN TWO, THREE & FOUR HORSE BUMPER PULL & GOOSENECK MODELS

Bigger is Better...When it's not the price!



SPECIFICATIONS

2 HORSE MODEL

3 HORSE MODEL

4 HORSE MODEL

INSIDE HEIGHT.....	7'	7'	7'
OVERALL HEIGHT.....	8'3"	8'3"	8'3"
INSIDE WIDTH.....	6'8"	6'8"	6'8"
OVERALL WIDTH.....	8'5"	8'5"	8'5"
FLOOR HEIGHT.....	14"	15"	15"
OVERALL LENGTH.....	16'3"	20'3"	22'3"
TRAILER BODY LENGTH.....	12'10"	16'10"	18'10"
TANDEM AXLES.....	3500#	5200#	5200#
WHEELS.....	White Modular 5-Lug.....	White Modular 6-Lug.....	White Modular 6-Lug
TIRES.....	ST205/75-15/LR-C.....	ST225/75-15/LR-D.....	ST225/75-15/LR-D
COUPLER.....	2 5/16" Bulldog.....	2 5/16" Bulldog.....	2 5/16" Bulldog
BRAKES.....	10" - 4 Wheel Electric.....	12" - 4 Wheel Electric.....	12" - 4 Wheel Electric
EMPTY WEIGHT.....	2700#.....	3625#.....	3850#
HITCH WEIGHT.....	300#.....	425#.....	500#
PAYLOAD CAPACITY.....	4300#.....	6374#.....	6149#
INTERIOR LIGHTS.....	(2) 1 Horse Stall & 1 Tack Room.....	(2) 1 Horse Stall & 1 Tack Room.....	(3) 2 Horse Stall & 1 Tack Room
BRIDLE HOOKS.....	(6).....	(6).....	(6)
BLANKET BARS.....	(2).....	(2).....	(2)
SADDLE RACKS.....	(2) Racks / Stationary.....	(3) Racks / Stationary.....	(4) Racks / Stationary
ALUMINUM DIAMOND PLATE.....	Front & Fender Overlay.....	Front & Fender Overlay.....	Front & Fender Overlay
RUBBER DOCK BUMPERS.....	3".....	3".....	3"
ROOF BOWS.....	w/ Flow Coat Galvanized.....	w/ Flow Coat Galvanized.....	w/ Flow Coat Galvanized
FRONT BOWS.....	Pre-Primered Steel.....	Pre-Primered Steel.....	Pre-Primered Steel
ELECTROGALVANIZED SHEET METAL.....	#3 Galvanized Finish.....	#3 Galvanized Finish.....	#3 Galvanized Finish
LOCKABLE REAR DOOR.....	Single Enclosed.....	Single Enclosed.....	Single Enclosed
ANGLE WALL.....	Removable.....	Removable.....	Removable
PADDED DIVIDERS.....	(1).....	(2).....	(3)
PLEXIGLASS.....	Kickwall.....	Kickwall.....	Kickwall
FEED DOOR WINDOWS.....	(2) 30" x 20" Drop.....	(3) 30" x 20" Drop.....	(4) 30" x 20" Drop
CAULKING PACKAGE.....	Full.....	Full.....	Full
FLOOR MATS.....	Full 1/2" Thick.....	Full 1/2" Thick.....	Full 1/2" Thick
VINYL PACKAGE.....	Standard.....	Standard.....	Standard

*Standard features are subject to change without notification.



TWO HORSE MODEL

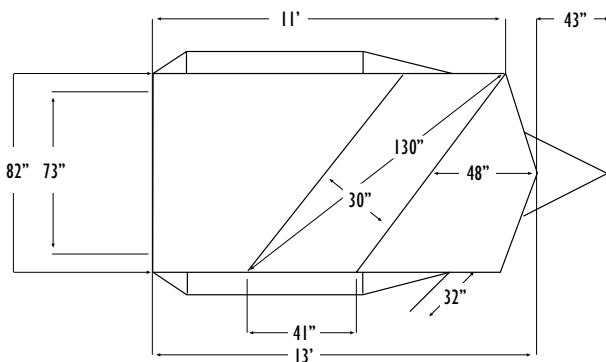

THREE HORSE MODEL

